

LTE in a Nutshell:

The Physical Layer

WHITE PAPER

OVERVIEW

The design of the LTE physical layer (PHY) is heavily influenced by the requirements for high peak transmission rate (100 Mbps DL/50 Mbps UL), spectral efficiency, and multiple channel bandwidths (1.25-20 MHz). To fulfill these requirements, orthogonal frequency division multiplex (OFDM) was selected as the basis for the PHY layer. OFDM is a technology that dates back to the 1960's. It was considered for 3G systems in the mid-1990s before being determined too immature. Developments in electronics and signal processing since that time has made OFDM a mature technology widely used in other access systems like 802.11 (WiFi) and 802.16 (WiMAX) and broadcast systems (Digital Audio/Video Broadcast – DAB/DVB).

In addition to OFDM, LTE implements multiple-antenna techniques such as MIMO (multiple input multiple output) which can either increase channel capacity (spatial multiplexing) or enhance signal robustness (space frequency/time coding).

Together, OFDM and MIMO are two key technologies featured in LTE and constitute major differentiation over 3G systems which are based on code division multiple access (CDMA). This whitepaper presents an overview of the LTE physical layer which in itself is a very large and feature-rich topic, particularly as there are different modes of operation (FDD/TDD) and different downlink and uplink access technologies (OFDMA, SC-FDMA), along with options and exceptions for each mode and access technology. To narrow the scope, this paper will focus on essential aspects of the physical layer for FDD mode which is the dominant mode of operation and selected by incumbent mobile operators as it fits well into existing and perspective spectrum assignments. Furthermore, the topic of MIMO is left out and is a subject to a separate whitepaper. It is hoped that this paper will serve as a useful introduction to practitioners involved in designing LTE based-networks and systems such as network engineers, product managers and technical managers.

MULTIPLE ACCESS TECHNIQUES

The OFDM technology is based on using multiple narrow band sub-carriers spread over a wide channel bandwidth. The sub-carriers are mutually orthogonal in the frequency domain which mitigates intersymbol interference (ISI) as shown in Figure 1. Each of these sub-carriers experiences 'flat fading' as they have a bandwidth smaller than the mobile channel coherence bandwidth. This obviates the need for complex frequency equalizers which are featured in 3G technologies.

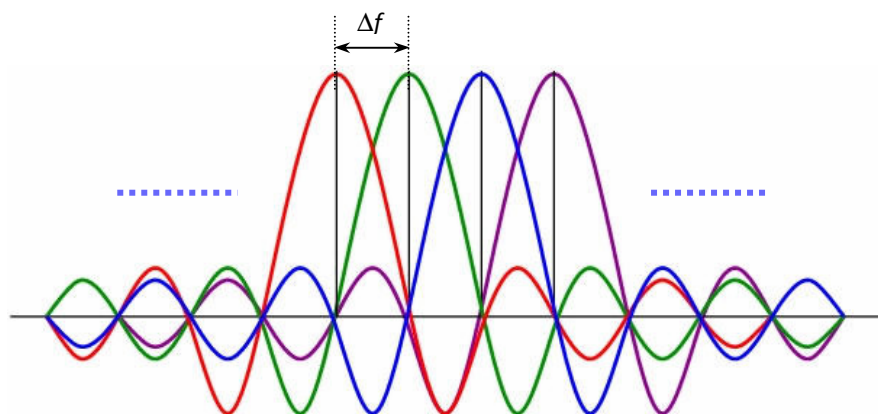

FIGURE 1 OFDM SUBCARRIER SPACING.

The information data stream is parallelized and spread across the sub-carriers for transmission. The process of modulating data symbols and combining them is equivalent to an Inverse Fourier Transform operation (IFFT). This results in an OFDM symbol of duration T_u which is termed 'useful symbol length'. In the receiver, the reverse operation is applied to the OFDM symbol to retrieve the data stream – which is equivalent to a Fast Fourier Transform operation (FFT).

The mobile propagation channel is typically time dispersive: multiple replicas of a transmitted signal are received with various time delays due to multipath resulting from reflections the signal incurs along the path between the transmitter and receiver. Time dispersion is equivalent to a frequency selective channel frequency response. This leads to at least a partial loss of orthogonality between sub-carriers. The result is intersymbol interference not only within a sub-carrier, but also between sub-carriers. To prevent an overlapping of symbols and reduce intersymbol interference, a guard interval T_g is added at the beginning of the OFDM symbol. The guard time interval, or cyclic prefix (CP) is a duplication of a fraction of the symbol end. The total symbol length becomes $T_s = T_u + T_g$. This makes the OFDM symbol insensitive to time dispersion.

There are many advantages to using OFDM in a mobile access system, namely:

- 1- Long symbol time and guard interval increases robustness to multipath and limits intersymbol interference.
- 2- Eliminates the need for intra-cell interference cancellation.
- 3- Allows flexible utilization of frequency spectrum.
- 4- Increases spectral efficiency due to orthogonality between sub-carriers.
- 5- Allows optimization of data rates for all users in a cell by transmitting on the best (i.e. non-faded) sub-carriers for each user.

This last feature is the fundamental aspect of OFDMA: the use of OFDM technology to multiplex traffic by allocating specific patterns of sub-carriers in the time-frequency space to different users. In addition to data traffic, control channels and reference symbols can be interspersed. Control channels carry information on the network and cell while reference symbols assist in determining the propagation channel response.

The downlink physical layer of LTE is based on OFDMA. However, despite its many advantages, OFDMA has certain drawbacks such as high sensitivity to frequency offset (resulting from instability of electronics and Doppler spread due to mobility) and high peak-to-average power ratio (PAPR). PAPR occurs due to random constructive addition of sub-carriers and results in spectral spreading of the signal leading to adjacent channel interference. It is a problem that can be overcome with high compression point power amplifiers and amplifier linearization techniques. While these methods can be used on the base station, they become expensive on the User Equipment (UE). Hence, LTE uses Single Carrier FDMA (SC-FDMA) with cyclic prefix on the uplink which reduces PAPR as there is only a single carrier as opposed to N carriers. Figure 2 illustrates the concepts of OFDMA and SC-FDMA.

For practicality, SC-OFDMA is implemented in LTE using a Discrete Fourier Transform Spread OFDM transmission (DFTS-OFDM) which is commonly referred to as a frequency-domain generalization of SC-FDMA. The DFT is used to multiplex uplink transmissions in specific frequency allocation blocks within the overall system bandwidth according to eNodeB scheduler instructions. The bandwidth of the single carrier is determined based on the required data rate by the user. Data remains serial and not parallelized as done on the downlink with OFDMA (i.e. one information bit is being transmitted at a time). This leads to similar link performance parameters for the uplink

and downlink. However, there would be relatively high intersymbol interference for the uplink due to the single carrier modulation. This requires a low-complexity block equalizer at the eNodeB receiver to correct for the distorting effects of the radio channel. SC-FDMA is not as sensitive to frequency instability and Doppler Effect as OFDM because of its single carrier nature.

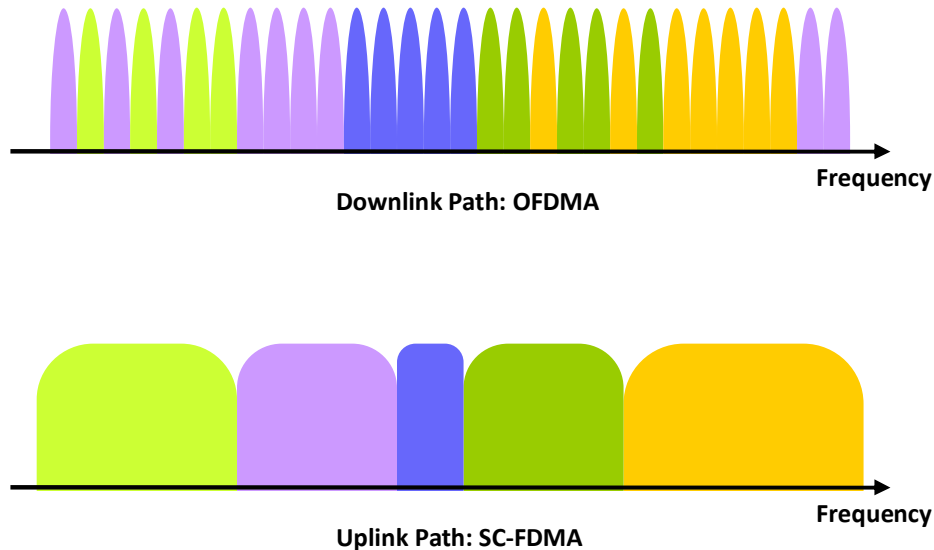

FIGURE 2 FREQUENCY DOMAIN REPRESENTATION OF DOWNLINK AND UPLINK LTE ACCESS TECHNOLOGIES.

PHYSICAL LAYER PARAMETERS

In the time domain, different time intervals within LTE are expressed as multiples of a basic time unit $T_s = 1/30720000$. The radio frame has a length of 10 ms ($T_{\text{frame}} = 307200 \cdot T_s$). Each frame is divided into ten equally sized subframes of 1 ms in length ($T_{\text{subframe}} = 30720 \cdot T_s$). Scheduling is done on a subframe basis for both the downlink and uplink. Each subframe consists of two equally sized slots of 0.5 ms in length ($T_{\text{slot}} = 15360 \cdot T_s$). Each slot in turn consists of a number of OFDM symbols which can be either seven (normal cyclic prefix) or six (extended cyclic prefix). Figure 3 shows the frame structure for LTE in FDD mode (Frame Structure Type 1).

The useful symbol time is $T_u = 2048 \cdot T_s \approx 66.7 \mu\text{s}$. For the normal mode, the first symbol has a cyclic prefix of length $T_{\text{CP}} = 160 \cdot T_s \approx 5.2 \mu\text{s}$. The remaining six symbols have a cyclic prefix of length $T_{\text{CP}} = 144 \cdot T_s \approx 4.7 \mu\text{s}$. The reason for different CP length of the first symbol is to make the overall slot length in terms of time units divisible by 15360. For the extended mode, the cyclic prefix is $T_{\text{CP-e}} = 512 \cdot T_s \approx 16.7 \mu\text{s}$. The CP is longer than the typical delay spread of a few microseconds typically encountered in practice as shown in Figure 4. The normal cyclic prefix is used in urban cells and high data rate applications while the extended cyclic prefix is used in special cases like multi-cell broadcast and in very large cells (e.g. rural areas, low data rate applications).

The CP uses up part of the physical layer capacity: 7.5% in the case of normal cyclic prefix. One way to reduce the relative overhead due to cyclic-prefix insertion is to reduce the sub-carrier spacing Δf , with a corresponding increase in the symbol time T_u as a consequence. However, this will increase the sensitivity of the OFDM transmission to frequency instability resulting from fast channel variations (i.e. high Doppler spread) as well as different types of frequency errors due to electronics.

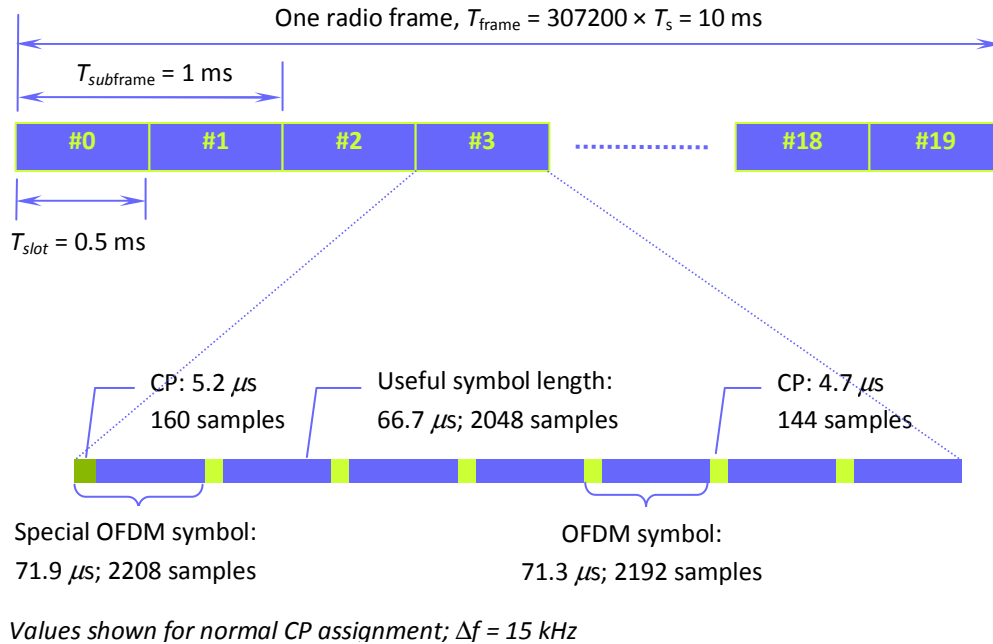

FIGURE 3 FRAME STRUCTURE TYPE 1 (FDD FRAME).

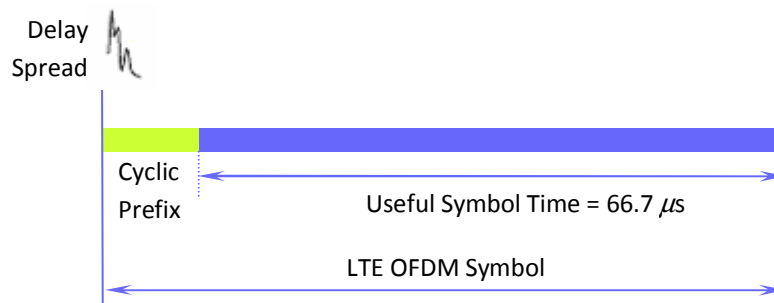

FIGURE 4 SYMBOL STRUCTURE.

In the frequency domain, the number of sub-carriers N ranges from 128 to 2048, depending on channel bandwidth with 512 and 1024 for 5 and 10 MHz, respectively, being most commonly used in practice. The sub-carrier spacing is $\Delta f = 1/T_u = 15 \text{ kHz}$. The sampling rate is $f_s = \Delta f \cdot N = 15000 N$. This results in a sampling rate that's multiple or sub-multiple of the WCDMA chip rate of 3.84 Mcps: LTE parameters have been chosen such that FFT lengths and sampling rates are easily obtained for all operation modes while at the same time ensuring the easy implementation of dual-mode devices with a common clock reference. Table 1 summarizes some of the main physical layer parameters for LTE in FDD mode.

Not all the sub-carriers are modulated (i.e. used). The DC sub-carrier is not used as well as sub-carriers on either side of the channel band: approximately 10% of sub-carriers are used as guard carriers.

In a macrocell, the coherence bandwidth of the signal is in the order of 1 MHz. Within the LTE carrier bandwidth of up to 20 MHz there are some sub-carriers that are faded and other are not faded. Transmission is done using those

frequencies that are not faded. The transmission can be scheduled by Resource Blocks (RB) each of which consists of 12 consecutive sub-carriers, or 180 kHz, for the duration of one slot (0.5 ms). This granularity is selected to limit signaling overhead. A Resource Element (RE) is the smallest defined unit which consists of one OFDM sub-carrier during one OFDM symbol interval. Each Resource Block consists of $12 \cdot 7 = 84$ Resource Elements in case of normal cyclic prefix (72 for extended CP). Figure 5 illustrates the definition of Resource Blocks and Resource Elements.

TABLE 1 LTE DOWNLINK PHYSICAL LAYER PARAMETERS.

Channel Bandwidth (MHz)	1.25	2.5	5	10	15	20
Frame Duration (ms)	10					
Subframe Duration (ms)	1					
Sub-carrier Spacing (kHz)	15					
Sampling Frequency (MHz)	1.92	3.84	7.68	15.36	23.04	30.72
FFT Size	128	256	512	1024	1536	2048
Occupied Sub-carriers (inc. DC sub-carrier)	76	151	301	601	901	1201
Guard Sub-carriers	52	105	211	423	635	847
Number of Resource Blocks	6	12	25	50	75	100
Occupied Channel Bandwidth (MHz)	1.140	2.265	4.515	9.015	13.515	18.015
DL Bandwidth Efficiency	77.1%	90%	90%	90%	90%	90%
OFDM Symbols/Subframe	7/6 (short/long CP)					
CP Length (Short CP) (μ s)	5.2 (first symbol) / 4.69 (six following symbols)					
CP Length (Long CP) (μ s)	16.67					

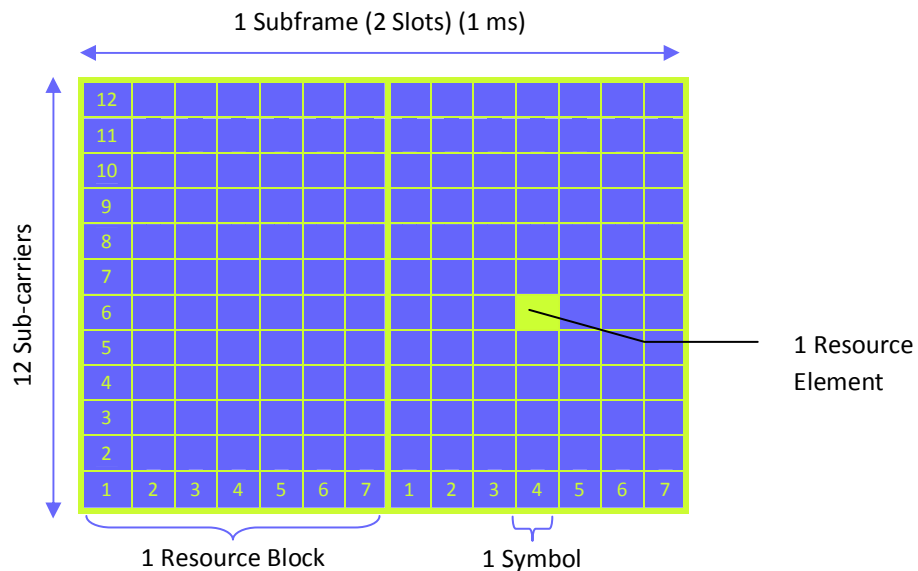

FIGURE 5 RESOURCE BLOCK AND RESOURCE ELEMENT DEFINITION (NORMAL CP MODE).

The uplink transmission structure is similar to the downlink. The smallest unit of resource is the Resource Element which consists of one SC-FDMA data block length on one sub-carrier (permissible to use this term because DFT is used for pre-coding with a 15 kHz sub-carrier spacing). A resource block consists of 12 REs for the duration of a slot (0.5 ms). The minimum allocated bandwidth to a UE is, therefore, 180 kHz. Multiple resource blocks are assigned

consecutively in the frequency domain to a UE in the uplink while dispersed, non-consecutive assignment, is done on the downlink.

In the time domain, a 10 ms uplink frame consists of 10 one ms subframes and 20 slots. The supported uplink CP durations are the same as those of the downlink: normal CP of $4.69 \mu s$ and extended CP for $16.67 \mu s$ (duration of first CP in normal mode is $5.2 \mu s$, also similar to the downlink). A slot consists of 7 or 6 SC-FDMA symbols in case of normal or extended mode CP, respectively.

REFERENCE SIGNALS

DOWNLINK REFERENCE SIGNALS

To allow for coherent demodulation at the user equipment, reference symbols (or pilot symbols) are inserted in the OFDM time-frequency grid to allow for channel estimation. Downlink reference symbols are inserted within the first and third last OFDM symbol of each slot with a frequency domain spacing of six sub-carriers (this corresponds to the fifth and fourth OFDM symbols of the slot in case of normal and extended cyclic prefix, respectively) as shown in Figure 6 for an LTE system with one antenna in normal CP mode. Furthermore, there is a frequency domain staggering of three sub-carriers between the first and second reference symbols. Therefore, there are four reference symbols within each Resource Block. The user equipment will interpolate over multiple reference symbols to estimate the channel. In case of two transmit antennas, reference signals are inserted from each antenna where the reference signals on the second antenna are offset in the frequency domain by three sub-carriers. To allow the user equipment to accurately estimate the channel coefficients, nothing is transmitted on the other antenna at the same time-frequency location of reference signals.

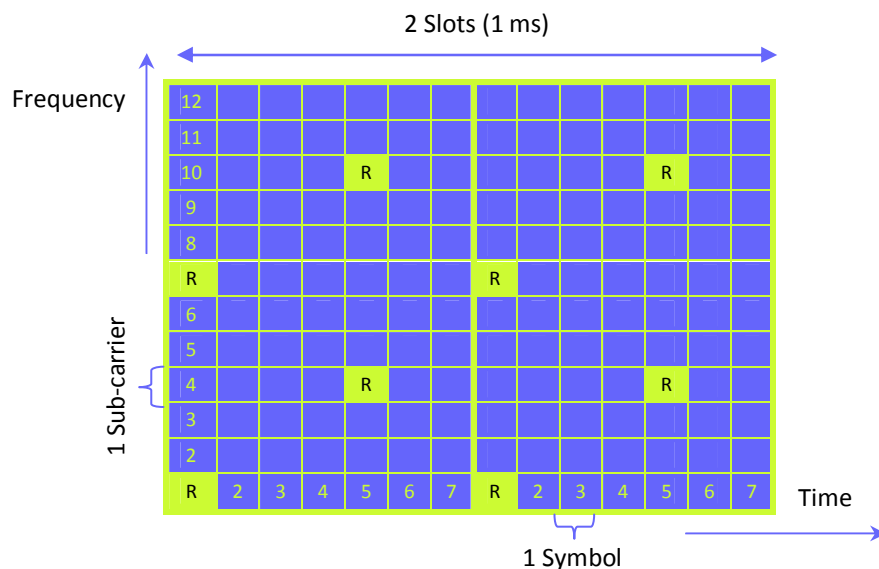

FIGURE 6 LOCATION OF REFERENCE SYMBOLS WITHIN A RESOURCE BLOCK FOR A ONE ANTENNA SYSTEM IN THE CASE OF A NORMAL CP.

The reference symbols have complex values which are determined according to the symbol position as well as of the cell. LTE specifications refer to this as a two-dimensional reference-signal sequence which indicates the LTE cell identity. There are 510 reference signal sequences corresponding to 510 different cell identities. The reference

signals are derived from the product of a two-dimensional pseudo-random sequence and a two-dimensional orthogonal sequence. There are 170 different pseudo-random sequences corresponding to 170 cell-identity groups, and three orthogonal sequences each corresponding to a specific cell identity within the cell identity group.

UPLINK REFERENCE SIGNALS

There are two types of reference signals for uplink in LTE. The first is Demodulation Reference Signals (DM-RS) which are used to enable coherent signal demodulation at the eNodeB. These signals are time multiplexed with uplink data and are transmitted on the fourth or third SC-FDMA symbol of an uplink slot for normal or extended CP, respectively, using the same bandwidth as the data.

The second is Sounding Reference Signal (SRS) which is used to allow channel dependent (i.e. frequency selective) uplink scheduling as the DM-RS cannot be used for this purposes since they are assigned over the assigned bandwidth to a UE. The SRS is introduced as a wider band reference signal typically transmitted in the last SC-FDMA symbol of a 1 ms subframe as shown in Figure 7. User data transmission is not allowed in this block which results in about 7% reduction in uplink capacity. The SRS is an optional feature and is highly configurable to control overhead – it can be turned off in a cell. Users with different transmission bandwidth share this sounding channel in the frequency domain.

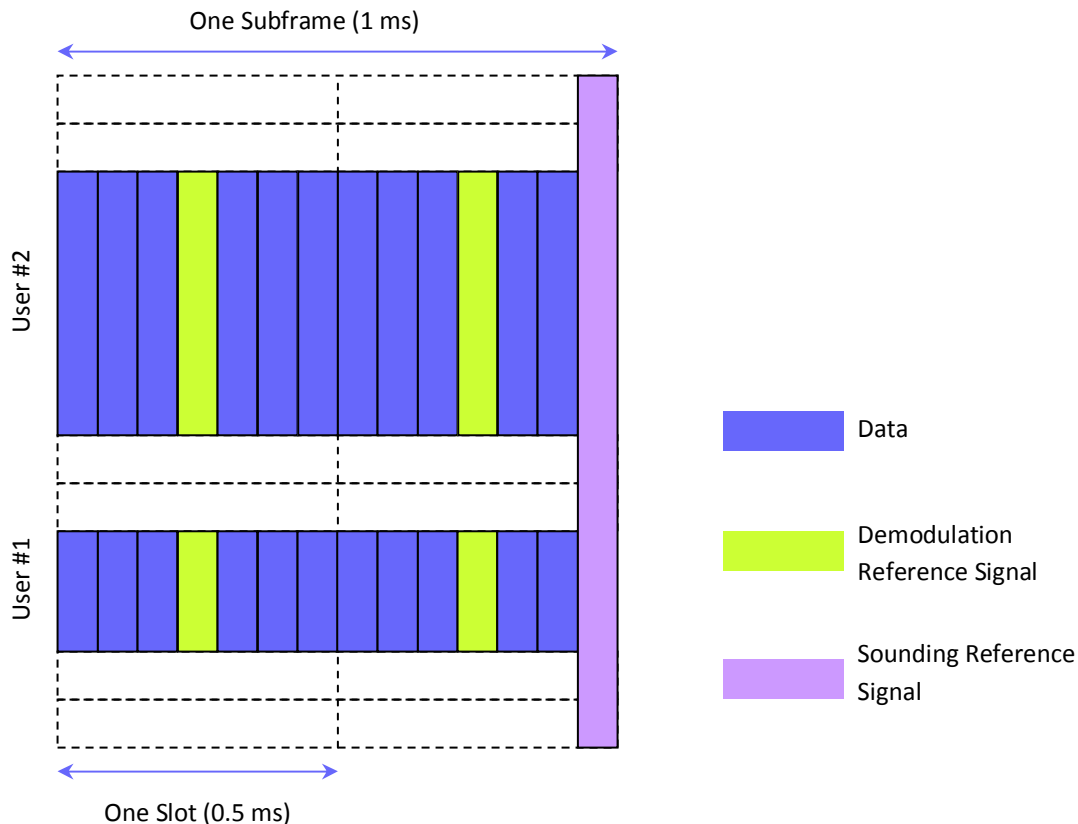

FIGURE 7 UPLINK DEMODULATION AND SOUNDING CHANNEL REFERENCE SIGNALS (NORMAL CP MODE).

SYNCHRONIZATION SEQUENCES

A User Equipment wishing to access the LTE system follows a cell search procedure which includes a series of synchronization stages by which the UE determines time and frequency parameters that are necessary to demodulate downlink signals, to transmit with correct timing and to acquire some critical system parameters.

There are three synchronization requirements in LTE: symbol timing acquisition by which the correct symbol start is determined; carrier frequency synchronization which mitigates the effect of frequency errors resulting from Doppler shift and errors from electronics; and sampling clock synchronization.

There are two cell search procedures in LTE: one for initial synchronization and another for detecting neighbor cells in preparation for handover. In both cases, the UE uses two special signals broadcast on each cell: Primary Synchronization Sequence (PSS) and Secondary Synchronization Sequence (SSS). The detection of these signals allows the UE to complete time and frequency synchronization and to acquire useful system parameters such as cell identity, cyclic prefix length, and access mode (FDD/TDD). At this stage, the UE can also decode the Physical Broadcast Control Channel (PBCH) and obtain important system information.

Synchronization signals are transmitted twice per 10 ms radio frame. The PSS is located in the last OFDM symbol of the first and 11th slot of each radio frame which allows the UE to acquire the slot boundary timing independent of the type of cyclic prefix length. The PSS signal is the same for any given cell in every subframe in which it is transmitted (the PSS uses a sequence known as Zadoff-Chu).

The location of the SSS immediately precedes the PSS – in the before to last symbol of the first and 11th slot of each radio frame. The UE would be able to determine the CP length by checking the absolute position of the SSS. The UE would also be able to determine the position of the 10 ms frame boundary as the SSS signal alternates in a specific manner between two transmissions (the SSS uses a sequence known as M-sequences).

In the frequency domain, the PSS and SSS occupy the central six resource blocks, irrespective of the system channel bandwidth, which allows the UE to synchronize to the network without a priori knowledge of the allocated bandwidth. The synchronization sequences use 62 sub-carriers in total, with 31 sub-carriers mapped on each side of the DC sub-carrier which is not used. This leaves 5 sub-carriers at each extremity of the 6 central RBs unused.

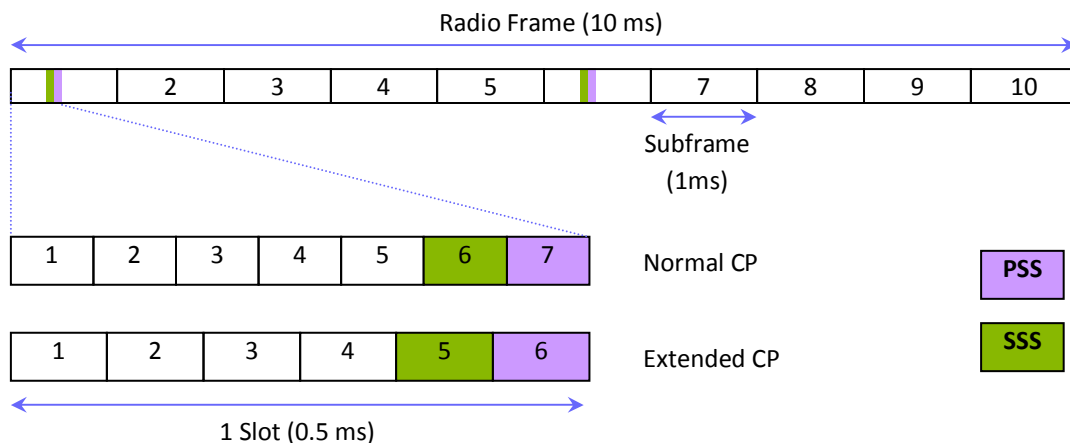

FIGURE 8 SYNCHRONIZATION SIGNAL FRAME AND SLOT STRUCTURE IN TIME DOMAIN.

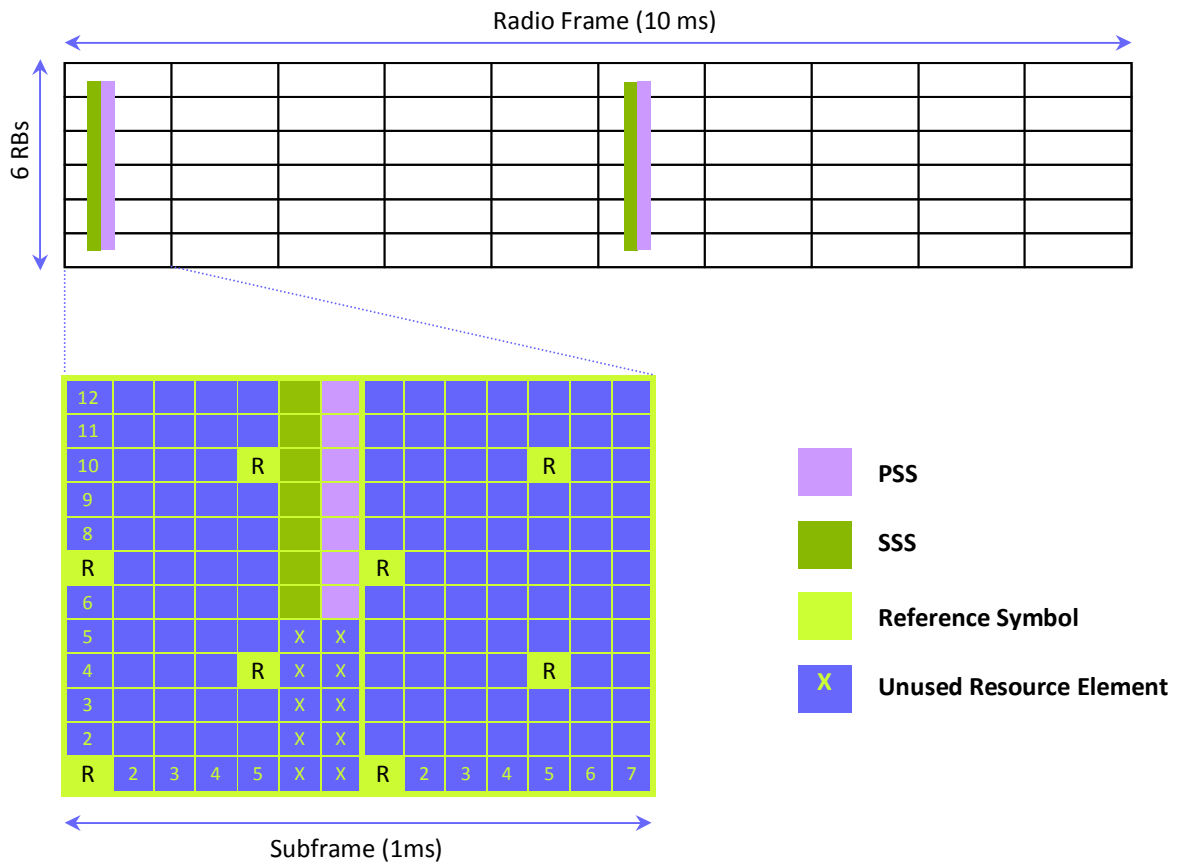

FIGURE 9 SYNCHRONIZATION SIGNALS FRAME STRUCTURE IN FREQUENCY AND TIME DOMAIN.

PHYSICAL CHANNELS

DOWNLINK PHYSICAL CHANNELS

LTE defines a number of downlink physical channels to carry information blocks received from the MAC and higher layers. These channels are categorized as transport or control channels.

TRANSPORT CHANNELS

- 1- **Physical Broadcast Channel (PBCH):** The PBCH broadcasts a limited number of parameters essential for initial access of the cell such as downlink system bandwidth, the Physical Hybrid ARQ Indicator Channel structure, and the most significant eight-bits of the System Frame Number. These parameters are carried in what's called a Master Information Block which is 14 bits long.

The PBCH is designed to be detectable without prior knowledge of system bandwidth and to be accessible at the cell edge. The MIB is coded at a very low coding rate and mapped to the 72 center sub-carriers (6 RBs) of the OFDM structure. PBCH transmission is spread over four 10 ms frames (over subframe #0) to span a 40 ms period as shown in Figure 10. Each subframe is self decodable which reduces latency and UE battery drain in case of good signal quality, otherwise, the UE would 'soft-combine' multiple transmissions

until the PBCH is decoded. The PBCH is transmitted using Space Frequency Block Code (SFBC), a form of transmit diversity, in case of multiple antennas thereby allowing for greater coverage.

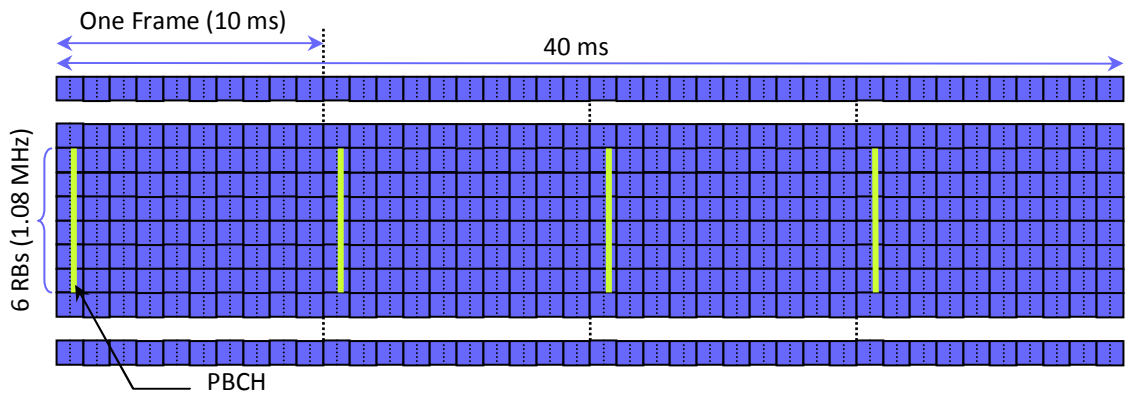

FIGURE 10 PBCH STRUCTURE.

- 2- **Physical Downlink Shared Channel (PDSCH):** The PDSCH is the main data bearing channel which is allocated to users on a dynamic and opportunistic basis. The PDSCH carries data in what's known as Transport Blocks (TB) which correspond to a MAC PDU. They are passed from the MAC layer to the PHY layer once per Transmission Time Interval (TTI) which is 1 ms (i.e. 1 ms scheduling interval to meet low latency requirements).

To guard against propagation channel errors, convolutional turbo coder is used for forward error correction. The data is mapped to spatial layers according to the type of multi-antenna technique (e.g. closed loop spatial multiplexing, open-loop, spatial multiplexing, transmit diversity, etc.) and then mapped to a modulation symbol which includes QPSK, 16 QAM and 64 QAM.

Physical resources are assigned on a basis on two resource blocks for one TTI (1 ms). This is referred to by 'pair of resource blocks' which is the quantum of resources that can be allocated. It corresponds to 12 sub-carriers (180 kHz) for 14 OFDM symbols (normal CP mode).

The PDCH is also used to transmit broadcast information not transmitted on the PBCH which include System Information Blocks (SIB) and paging messages.

- 3- **Physical Multicast Channel (PMCH):** This channel defines the physical layer structure to carry Multimedia Broadcast and Multicast Services (MBMS). However, MBMS are not included in the first release of LTE. The PMCH is designed for a single-frequency network and it requires that the base stations transmit with tight time synchronization the same modulated symbols. The PMCH is transmitted in specific dedicated subframes where the PDSCH is not transmitted.

CONTROL CHANNELS

Control occupy the first 1, 2, or 3 OFDM symbols in a subframe extending over the entire system bandwidth as shown in Figure 11. In narrow band systems (less than 10 RBs), the control symbols can be increased to include the fourth OFDM symbol.

- 1- **Physical Downlink Control Channel (PDCCH):** The PDCCH carries the resource assignment for UEs which are contained in a Downlink Control Information (DCI) message. Multiple PDCCHs can be transmitted in

the same subframe using Control Channel Elements (CCE) each of which is a nine set of four resource elements known as Resource Element Groups (REG). QPSK modulation is used for the PDCCH. Four QPSK symbols are mapped to each REG. Furthermore, 1, 2, 4, or 8 CCEs can be used for a UE depending on channel conditions to ensure sufficient robustness.

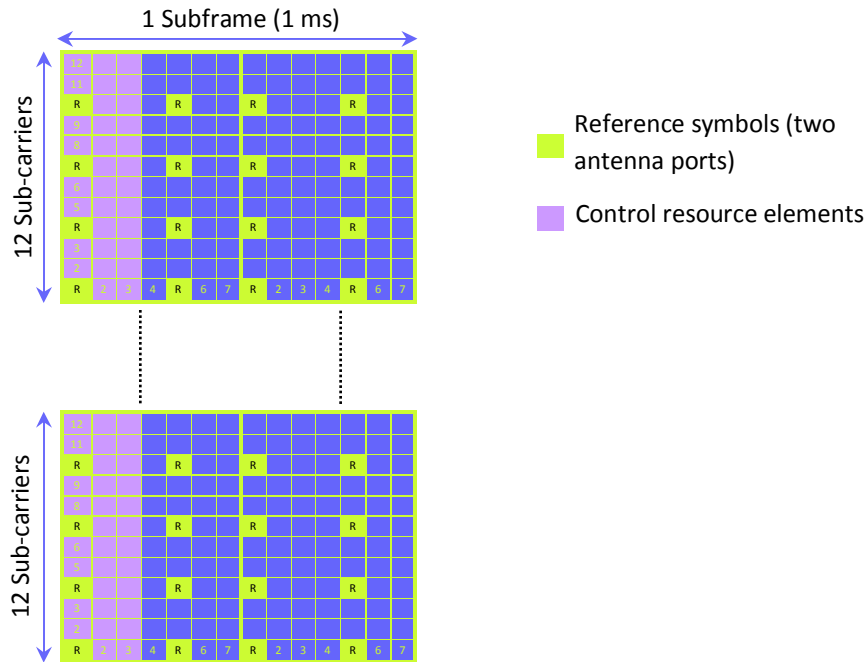

FIGURE 11 CONTROL CHANNEL SIGNALLING REGION (3 OFDM SYMBOL EXAMPLE).

- 2- **Physical Control Format Indicator Channel (PCFICH):** This channel carries the Control Frame Indicator (CFI) which includes the number of OFDM symbols used for control channel transmission in each subframe (typically 1, 2, or 3). The 32-bit long CFI is mapped to 16 Resource Elements in the first OFDM symbol of each downlink frame using QPSK modulation.
- 3- **Physical Hybrid ARQ Indicator Channel (PHICH):** The PHICH carries the HARQ ACK/NAK which indicates to the UE whether the eNodeB correctly received uplink user data carried on the PUSCH. BPSK modulation is used with repetition factor of 3 for robustness.

UPLINK PHYSICAL CHANNELS

There are three physical layer channels defined for the uplink in LTE as described below.

Physical Uplink Shared Channel (PUSCH): This channel carries user data. It supports QPSK and 16 QAM modulation with 64QAM being optional. Information bits are first channel-coded with a turbo code of mother rate of 1/3 before being adapted by a rate matching process for a final suitable code rate. Adjacent data symbols are mapped to adjacent SC-FDMA symbols in the time domain before being mapped across sub-carriers. After this interleaving process, bits are scrambled before modulation mapping, DFT-spreading, sub-carrier mapping and OFDM modulation. Channel coding is similar to that of the downlink.

The uplink scheduling interval is 1 ms, similar to the downlink. However, it is possible to ‘bundle’ a group of 4 TTIs to improve performance at cell edge and reduce higher layer protocol overhead. In this case, a MAC PDU is segmented for transmission over multiple TTIs. In the frequency domain, transmissions are allocated based on multiples of 180 kHz resource blocks. Uplink resources corresponding to the same set of sub-carriers are assigned for the two slots of a subframe. However, inter-slot frequency hopping is an option whereby different sub-carriers are used for the second slot resulting in a frequency diversity gain and averages interference provided different hopping sequences are used in neighboring cells.

The PUSCH carries in addition to user data any control information necessary to decode the information such as transport format indicators and MIMO parameters. Control data is multiplexed with information data prior to DFT spreading.

Physical Uplink Control Channel (PUCCH): Control signaling comprises uplink data transmitted independently of traffic data which include HARQ ACK/NACK, channel quality indicators (CQI), MIMO feedback (Rank Indicator, RI; Precoding Matrix Indicator, PMI) and scheduling requests for uplink transmission. This channel transmits in a frequency region at the edge of the system bandwidth as shown in Figure 12. It consists of one RB per transmission at one end of the system bandwidth followed by a RB in the following slot at the opposite end of the channel spectrum thus making use of frequency diversity with an estimated gain of 2 dB. A PUCCH Control Region comprises every two such RBs. Table 2 shows the typical number of PUCCH regions for different system bandwidths. BPSK or QPSK are used for modulation of PUCCH information.

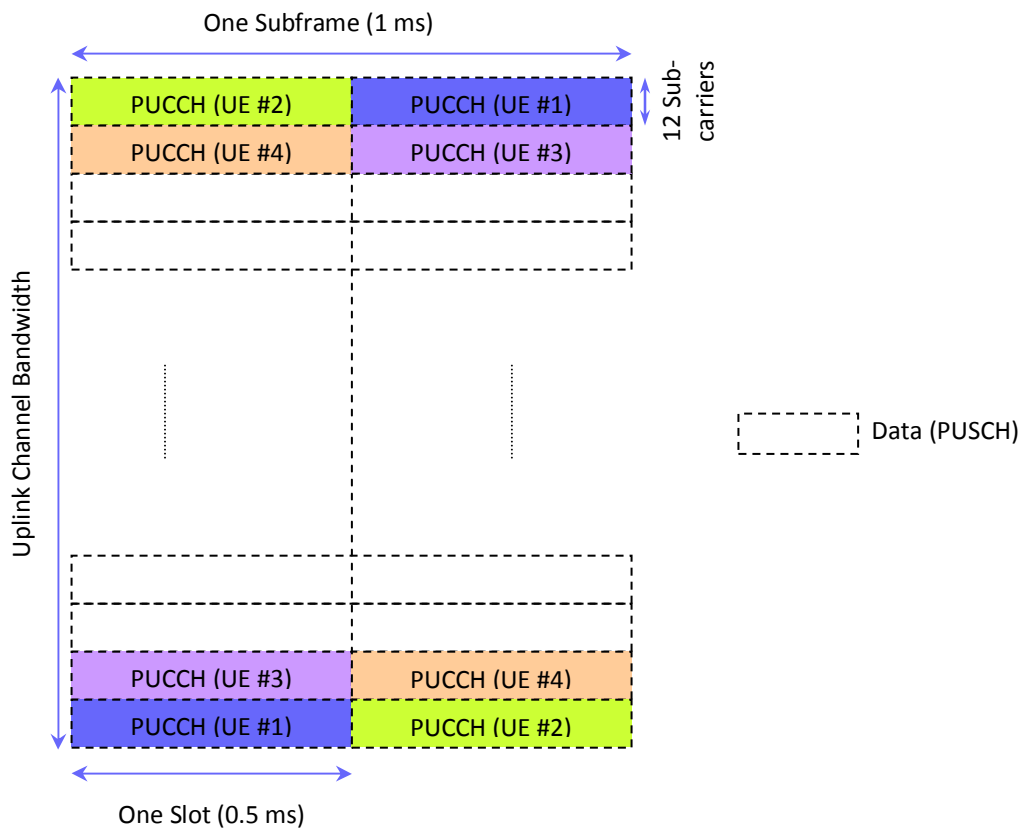

FIGURE 12 PHYSICAL UPLINK CONTROL CHANNEL STRUCTURE.

TABLE 2 TYPICAL NUMBER OF PUCCH REGIONS.

System Bandwidth (MHz)	1.25	2.5	5	10	15	20
PUCCH Control Regions	1	2	4	8	12	16
Number of Resource Blocks	2	4	8	16	24	32

Physical Random Access Channel (PRACH): This channel carries the random access preamble a UE sends to access the network in non-synchronized mode and used to allow the UE to synchronize timing with the eNodeB. It consists of 72 sub-carriers in the frequency domain (six Resource Block, 1.08 MHz) as shown in Figure 13. FDD LTE defines four different Random Access (RA) preamble formats with different preamble and cyclic prefix duration to accommodate different cell sizes. Preamble Format 0, which is well suited for small to medium size cells (up to approximately 14 km), uses a full 1 ms subframe and has a preamble duration of 800 μ s with 103 μ s cyclic prefix and 97 μ s guard time, as shown in Figure 14.

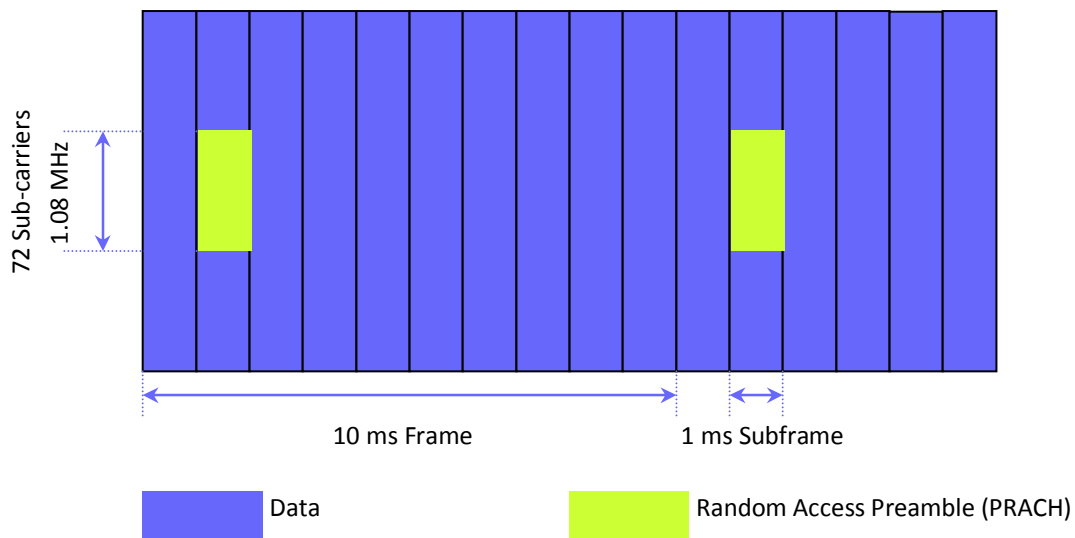

FIGURE 13 RANDOM ACCESS PREAMBLE TRANSMISSION.

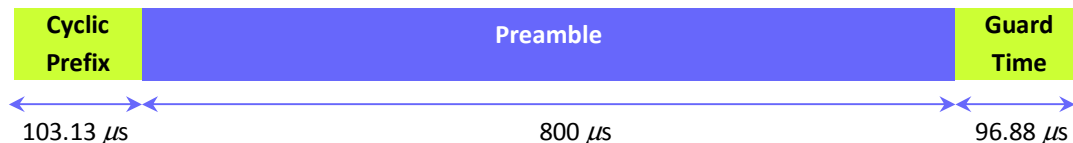

FIGURE 14 RANDOM ACCESS PREAMBLE.

CONCLUSIONS

The LTE physical layer implements a number of technologies to deliver on requirements for high data rates and spectral efficiency. OFDMA with MIMO allows the downlink to provide as high as 100 Mbps in link throughput while SC-FDMA on the uplink reduces design complexity for the user terminals by reducing PAPR. The design of the

physical layer and system parameters are well matched with the characteristics of mobile propagation channel to allow optional downlink and uplink frequency selective scheduling thereby enhancing throughput performance. Adaptive modulation and coding maximizes throughput to individual subscribers and increases overall cell capacity.

Aside from capacity, the physical layer is structured to provide low latency. The 1 ms subframe duration provides low latency through small scheduling intervals while maintaining low overhead related to higher layer protocols. The PHY is also well designed to provide high cell-edge performance with specific features such as dynamic bandwidth allocation to users and the design of reference signals and control channels which take into account more challenging path loss and interference environment at the cell edge.

ABBREVIATIONS AND ACRONYMS

3GPP	3rd Generation Partnership Project
ACK	Acknowledgment
ARQ	Automatic Repeat Request
CCE	Control Channel Elements
CDMA	Code Division Multiple Access
CP	Cyclic Prefix
CQI	channel quality indicators
DCI	Downlink Control Information
DFTS-OFDM	Discreet Fourier Transform – OFDM
DL	Downlink
DM-RS	Demodulation Reference Signals
FDD	Frequency Division Duplex
FFT	Fast Fourier Transform
HARQ	Hybrid Automatic Repeat Request
IFFT	Inverse Fast Fourier Transform
ISI	Intersymbol Interference
LTE	Long Term Evolution
MAC	Medium Access Control Layer
MBMS	Multimedia Broadcast and Multicast Services
MIB	Master Information Block
MIMO	Multiple Input Multiple Output
NACK	Negative Acknowledgment
OFDM	Orthogonal Frequency Division Multiplexing
OFDMA	Orthogonal Frequency Division Multiplex Access
PAPR	Peak-to-Average Power Ratio
PBCH	Physical Broadcast Channel
PCFICH	Physical Control Format Indicator Channel
PDCCH	Physical Downlink Control Channel
PDSCH	Physical Downlink Shared Channel
PDU	Protocol Data Unit
PHICH	Physical Hybrid ARQ Indicator Channel
PHY	Physical Layer
PMI	Precoding Matrix Indicator
PRACH	Physical Random Access Channel
PSS	Primary Synchronization Sequence
PUCCH	Physical Uplink Control Channel
PUSCH	Physical Uplink Shared Channel
RB	Resource Block
RE	Resource Element
REG	Resource Element Groups
RI	Rank Indicator
SC-FDMA	Single Carrier Frequency Division Multiple Access
SFBC	Space Frequency Block Code

SIB	System Information Block
SRS	Sounding Reference Signal
SSS	Synchronization Sequence
TB	Transport Block
TDD	Time Division Duplex
TTI	Transmission Time Interval
UE	User Equipment
UL	Uplink
UMTS	Universal Mobile Telecommunication System
WCDMA	Wideband Code Division Multiple Access

Corporate Headquarters

18 Byer Drive
Markham, ON L3P 6V9
Canada
+1.416.969.9570

Inquiries

Frank Rayal, CTO
+1.416.294.7211
frank@tsiwireless.com

For more information please visit

www.tsiwireless.com

Telesystem Innovations Inc. (TSI) is a leading telecommunications management and technical consulting firm focusing on broadband wireless system deployments and applications. Headquartered in Toronto, Canada, the company has served customers on a global basis and particularly in emerging markets because of the large demand for broadband wireless.

TSI services entities across the wireless network supply chain: equipment vendors, system integrators and network operators. TSI services are provided by a team of telecommunication industry professionals with expertise in managing large-scale wireless network buildout, optimization and expansion; product development, design and marketing; financial analysis and market research; and business development. TSI staff has contributed to the successful launch of several wireless networks on a worldwide scale including networks in Canada, the United States, Europe, the Middle East and Latin America.

Copyright ©2010 Telesystem Innovations Inc. All Rights Reserved. Information in this document is subject to change without notice. Telesystem Innovations assumes no responsibility for any errors that may appear in this document.

TSI 100402-004